



东莞伟易达电子产品有限公司

ERP项目选型、实施及其他

Apr 28, 2010



- 苏新
工学学士、MBA
- 资讯管理部 高级经理
- **Email: xin_su@vtech.com.cn**
samuelxinsu@gmail.com



公司简介

- 成立于1976年
- 总部在中国香港
- 2009财政年度集团营业额超过14亿美金
- 2009财政年度集团盈利超过1.4亿美金
- 股票代码：香港联合交易所-00303
美国预托证券-VTKHY
- 全球最大的有绳及无绳电话，以及电子学习产品供应商之一。同时提供备受推崇的承包生产服务

vtech



ERP选型

- 我们的考虑因素
 - 适用、较丰富的功能、不太复杂的系统
 - 开放的平台、主流的技术
 - 容易做客户化开发
 - 较高的性价比

ERP选型

- 企业需求与产品功能相匹配
 - 第一轮
 - 供应商情况需求书(RFI, Request for information)
 - 第二轮
 - 情景演示 (Scenario analysis)
 - 评估模型/评分表(Evaluation model/Score scheme)
 - 第三轮
 - 详细业务需求(Business Requirements)
 - 方案需求书(RFP, Request for proposal)
 - 报价需求书(RFQ, Request for quotation)
 - 评估模型/评分表 (Evaluation model/Score scheme)
 - 考察候选厂商的典型客户

ERP选型

- 参考中立机构的权威资料

- **TEC** (Technology Evaluation Center)

- www.technologyevaluation.com
 - 它提供非常详细的产品功能评分，针对绝大部分ERP产品
 - 比较少国内产品

- **MBT** (Manufacturing Business Technology)

- www.mbtmag.com
 - 它提供IT厂商的综合排名，但每年的排名方式并不相同

- **Gartner Group**

- www.gartner.com
 - 它利用象限图 (Magic Quadrant) 的方式宏观地比较和分析各个ERP产品，它的报告并非每年都有



Magic Quadrant for the ERP Manufacturing Midmarket (Jun 2005)

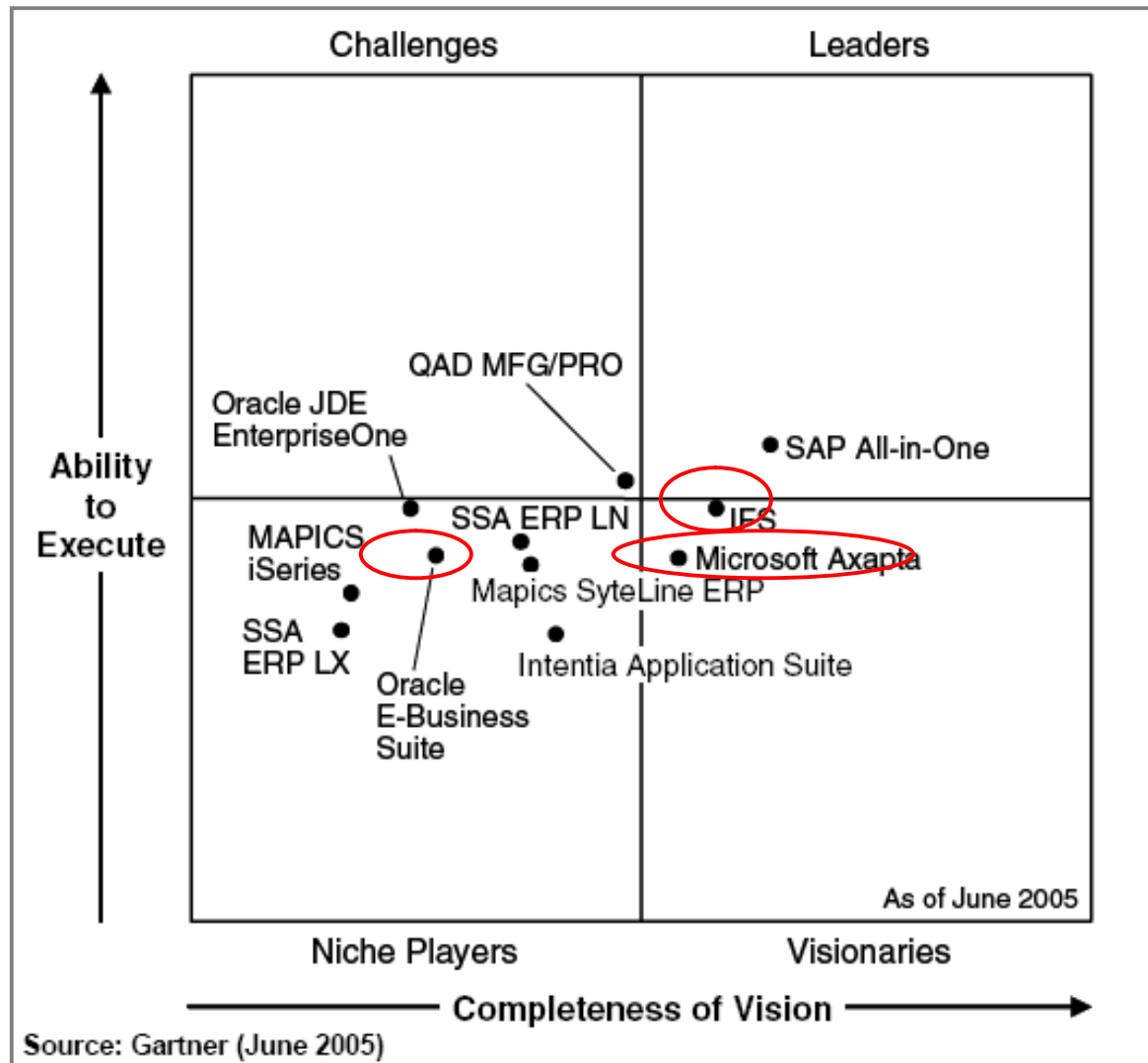



Gartner Group评论某个ERP产品

IFS: This vendor offers component-based technology and deep functionality for complex discrete manufacturers in the aviation/defense, automotive, industrial manufacturing, medical device, high-technology and process industries. A benefit for IFS customers is the vendor's ability to deliver lower total cost of ownership (TCO) after initial implementation, compared with other ERP vendors. Because IFS supplies a componentized product, no large-scale upgrades are required, and users can deploy functionality on demand. Because IFS operates somewhat autonomously at the country level, if you're considering a global implementation of IFS products, you need to ensure a country focus in your specific industry.

However, IFS's financial performance has caused users to question the vendor's continued viability. IFS must return to profitability by continuing its cost-containment initiatives, focusing on its core competencies, and stressing performance in the U.S. market. In addition, IFS does not have a global brand identity; therefore, it is often ignored in many deals. Users with discrete, engineer-to-order (ETO)-oriented requirements should evaluate IFS solutions, with the understanding that its industry-focused implementation expertise may vary across geographies.

ERP实施-成功并非轻而易举

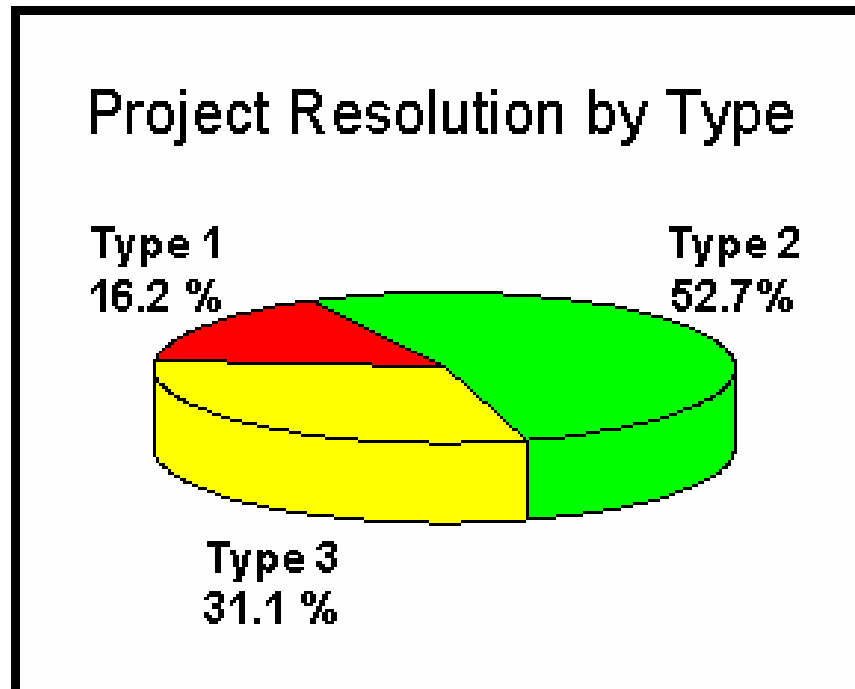

- 8,380 Projects
- Type 1: The project is completed on-time and on-budget, with all features and functions as initially specified.
- Type 2: The project is completed and operational but over-budget, over the time estimate, and offers fewer features and functions than originally specified.
- Type 3: The project is canceled at some point during the development cycle.
- Source: www.StandishGroup.com



ERP实施-成功并非轻而易举

项目不成功的因素

- **Incomplete Requirements** 13.1%
- **Lack of User Involvement** 12.4%
- **Lack of Resources** 10.6%
- **Unrealistic Expectations** 9.9%
- **Lack of Executive Support** 9.3%

项目成功的因素

- **User Involvement** 15.9%
- **Executive Management Support** 13.9%
- **Clear Statement of Requirements** 13%
- **Proper Planning** 9.6%
- **Realistic Expectations** 8.2%

ERP实施-我们的策略

- 尽量使用ERP的标准功能
- 保证重点的客户化开发
- 上线之后，逐步完善ERP系统
- 在资源投入、功能、上线日期这三方面取得平衡

	优先	约束	接受
资源		V	
发布日期	V		
功能			V

ERP实施-步骤

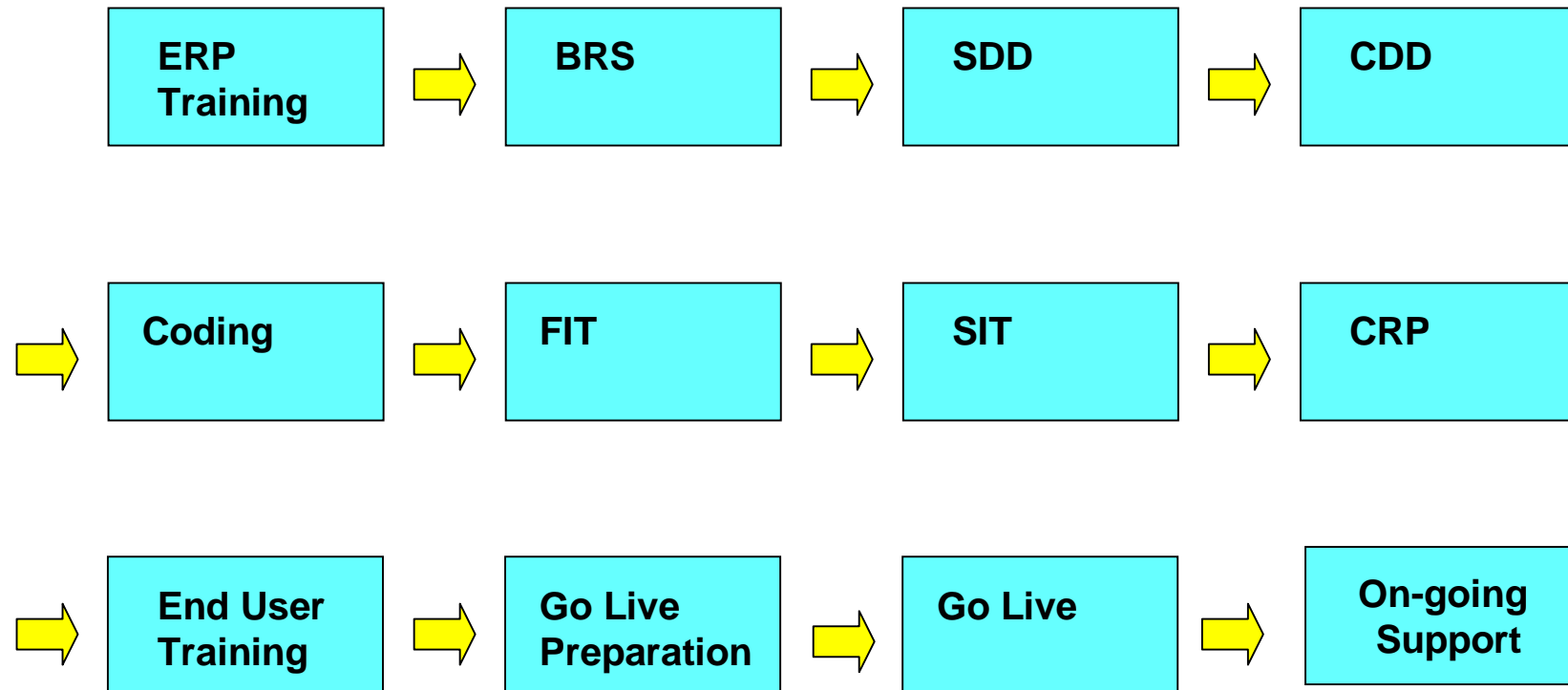



ERP实施-步骤

- **BRS – Business Requirement Study**
- **SDD – Solution Definition Documentation**
- **CDD – Customization Design Documentation**
- **FIT – Functional Individual Test**
- **SIT – System Integration Test**
- **CRP – Conference Room Pilot**



ERP实施-客户化开发

- 原MRPII应用了超过十年
- 原MRPII系统上做了大量的客户化开发
- 有些客户化开发反映了本公司运作特质
- 原MRPII 重要的客户化开发必须移植到ERP
- 部分重要的客户化开发
 - MRP计算
 - 物料代用
 - 发料系统

ERP实施-客户化开发

- **数据迁移(Data Migration)**
 - 我们迁移了大部分我们需要保留的数据，避免了用户在两套系统中查阅数据
 - 为保证系统的稳定，我们编写程序，模拟真实的场景，写入历史数据
- **系统接口(System Interface)**
 - 原MRPII系统与其他应用系统有大量接口，我们改写了这些接口，以便ERP系统与其他应用系统交互

vtech

HK

DG

New EXE

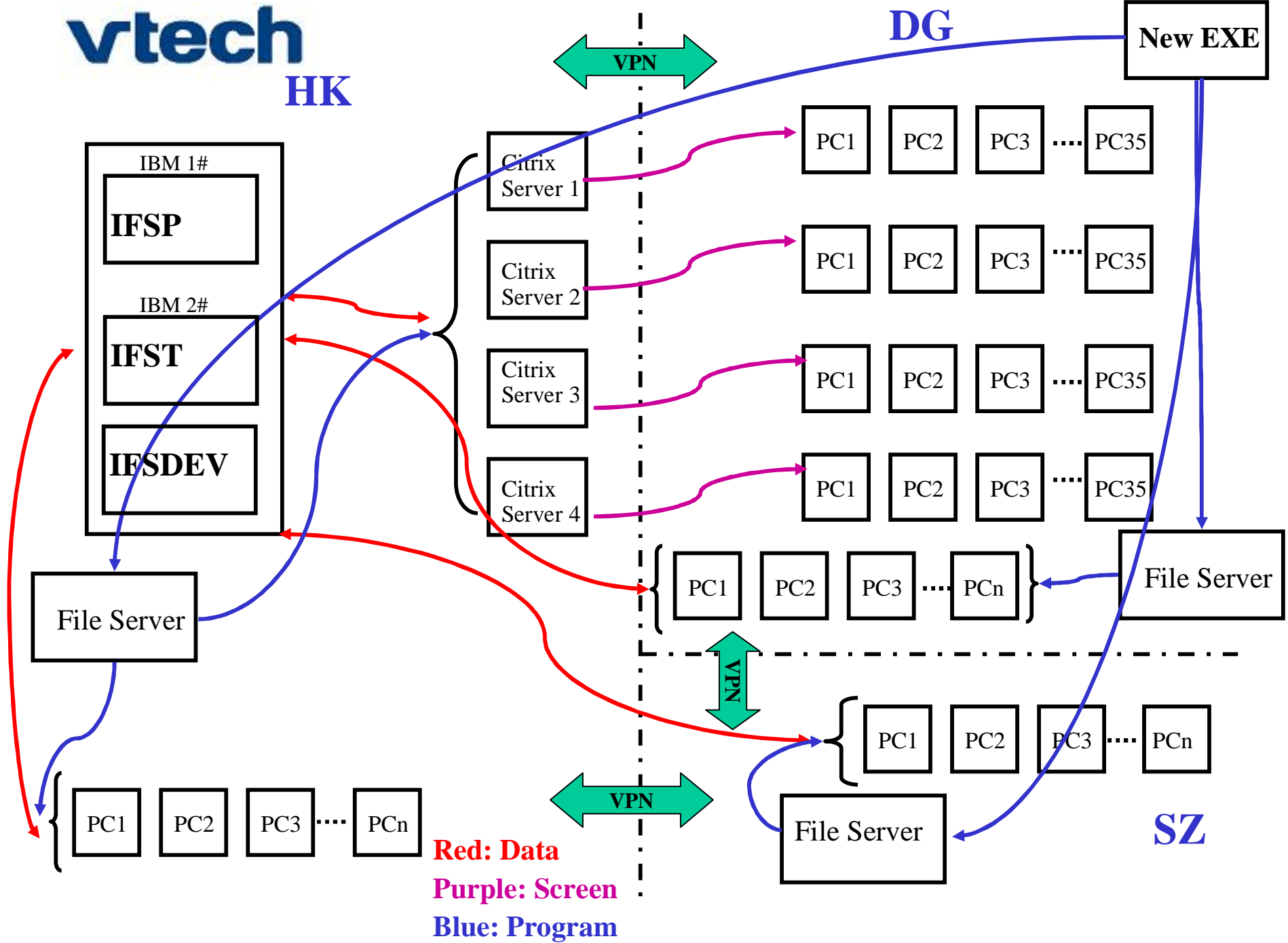

Red: Data
Purple: Screen
Blue: Program



ERP实施-一些数据

- 项目选型11个月、项目实施13个月
- 40名顾问、20名企业方核心项目成员
- 客户化开发超过6000人天
- 超过450个命名用户，约250个并发用户
- 28份SDD、106份CDD
- 5次SIT、3次CRP

ERP实施-结果

- 实现了由新ERP替代原有MRPII的目标，解除了原MRPII所依赖的数据库、操作系统、硬件等没有厂家支持并且随时可能崩溃的危机
- 项目费用在预算内
- 原MRPII持续十年的客户化开发，重点部分均顺利移植到ERP
- 一些关键运算的效率明显高于原来的MRPII。比如，物料需求计划原来是5小时，现在为1.5小时；发料系统原来为3小时，现在不到1小时。



ERP实施-结果

- 上线至今超过35个月，运行平稳
- 自2007年8月开始，我们不曾有任何关于ERP的问题需要ERP厂家解决!

对敏捷企业的思考

- 敏捷企业就是适应变化！更快地变化！
- 信息化是建设敏捷企业的基石
- ERP是信息化的重要组成部分
- 要做ERP的主人，而非奴隶
- 怎样才不做ERP的奴隶
 - 适用、不复杂的ERP系统
 - 选择非“SO SO”的ERP产品需要勇气
 - 开放的平台、主流的技术
 - 一支稳定的内部开发团队